

**LEGEND**

Cut to outlines indicated as follows

- ◄ 1/8" Balsa fuselage side
- ◄ 1/16" Plywood doubler
- ◄ 1/8" Balsa air intake/engine cover

**FUSELAGE**

1/4" balsa core with voids  
1/8" balsa sides  
1/16" ply doublers  
1/8" balsa air intakes/engine covers

**TAILFIN**

1/16" ply core  
3/32" balsa sides

**ECM HOUSING**

1/8" balsa

Note!  
Tailfin should be fitted after airframe is finished engine etc installed & correct C.G. achieved.

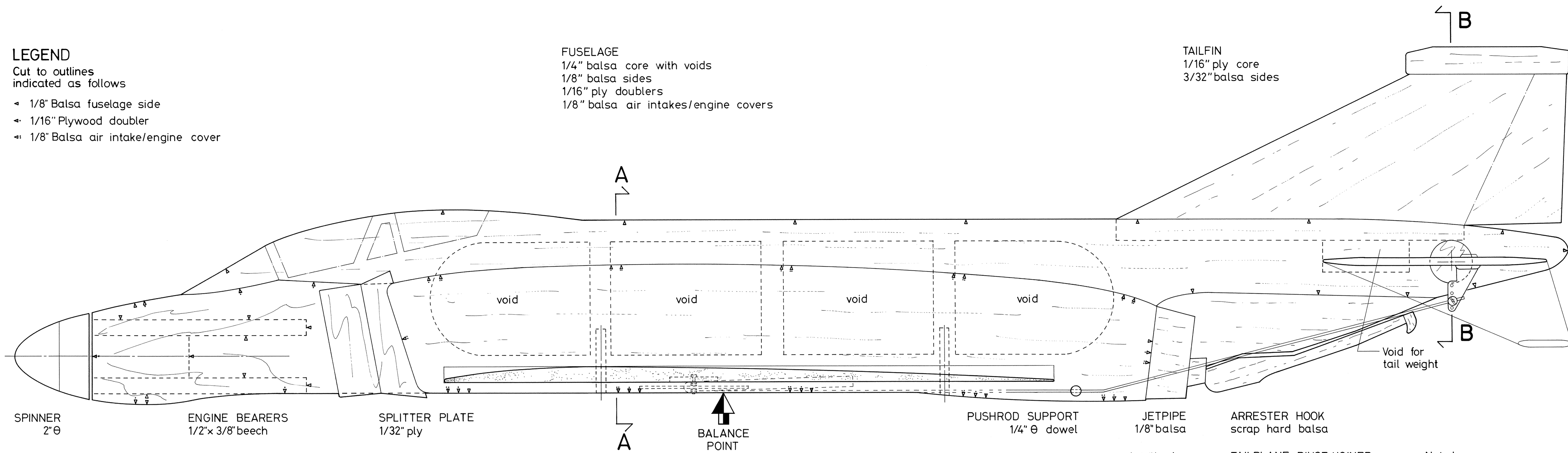

**SECTION AA**

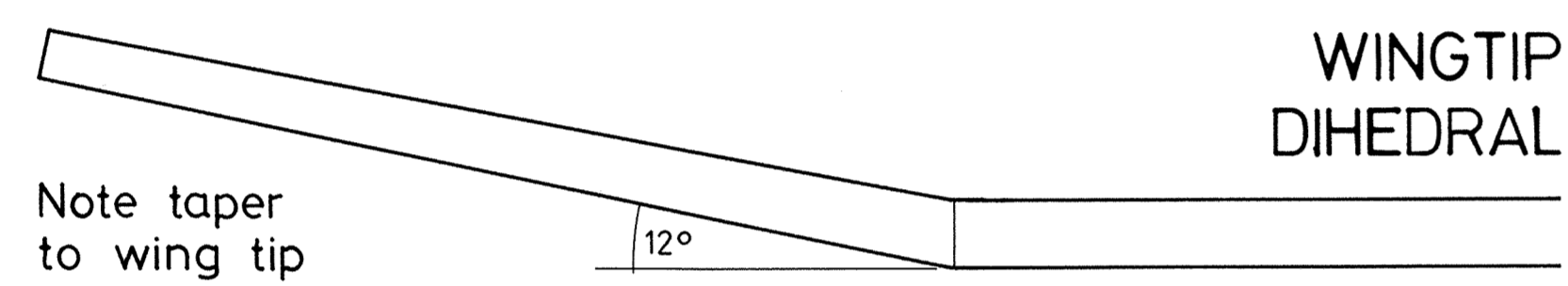
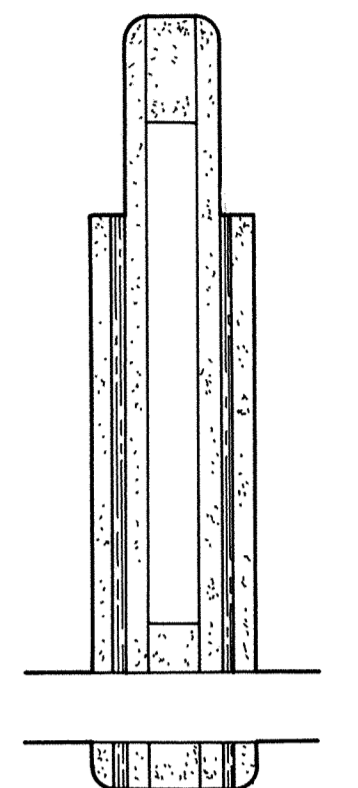

2" BELLCRANK MOUNTING PLATE 1/8" ply

LEADOUTS Heavyweight "Laystrate"

LEADOUT SUPPORT 1/4" Ø dowel checked into underside of wing & angled to clear leadouts.

WING 1/4" x 3/16" hard balsa leading edge 3" wide x 3/8" medium balsa sheets planed & sanded to section

PIN 1/4" Ø dowel

PIN 1/4" Ø dowel

PUSHROD Bicycle spoke

Lightweight glasscloth epoxied on top & bottom to strengthen joint

TAILPLANE 1/16" ply core 1/16" balsa top & bottom

Slot in ply for joiner

Note!  
Tailplane halves can be fitted after airframe is painted & fuelproofed.

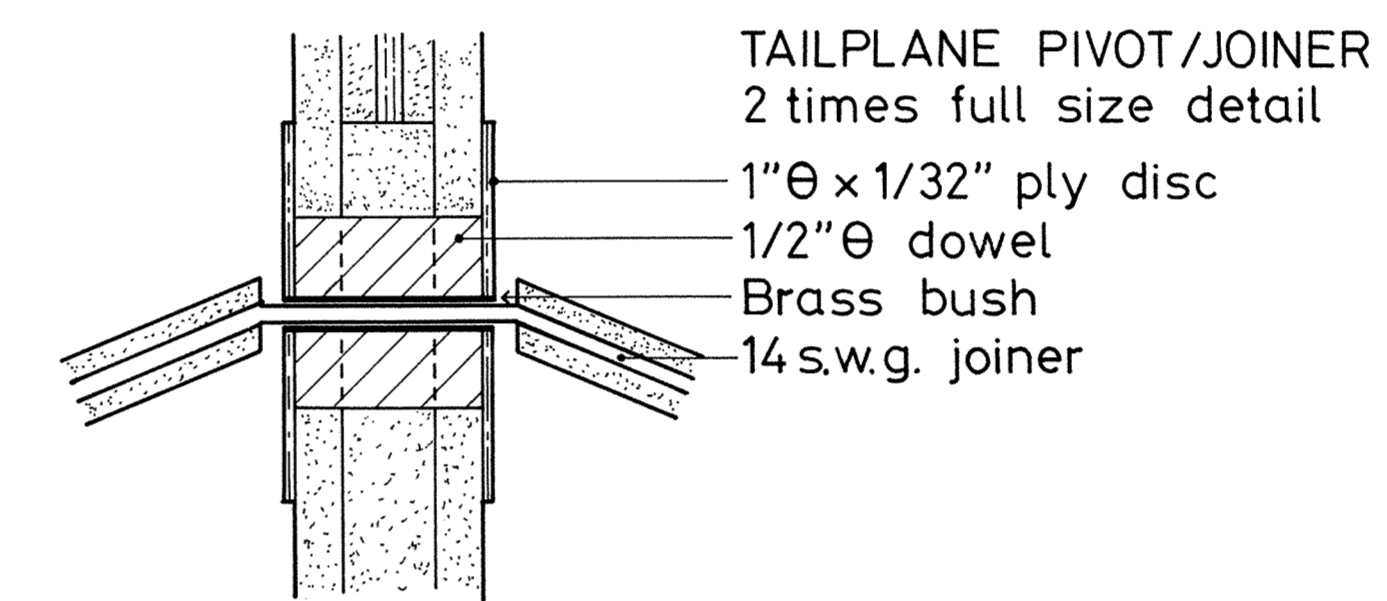

Note!  
Tailplane joiner should be well roughened with file to provide good key for "Araldite" adhesive when fitting tailplane halves.

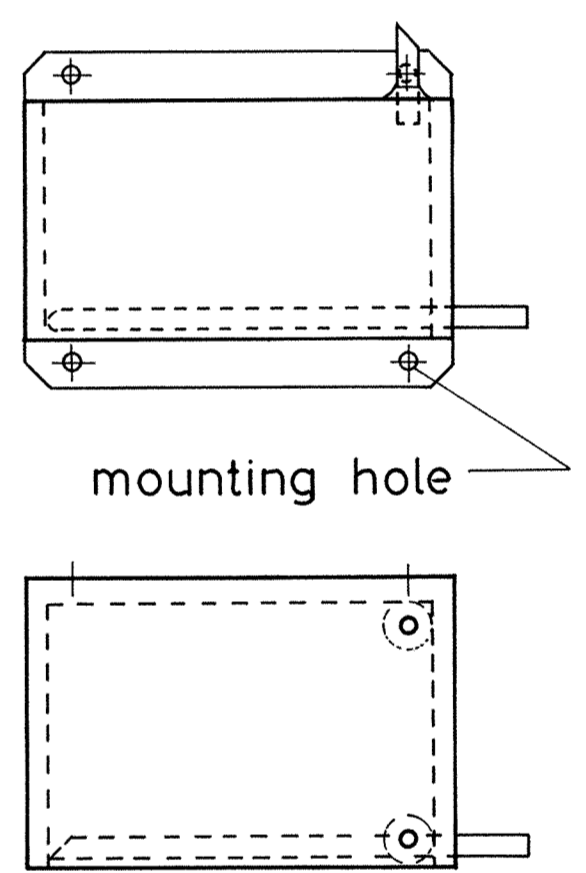
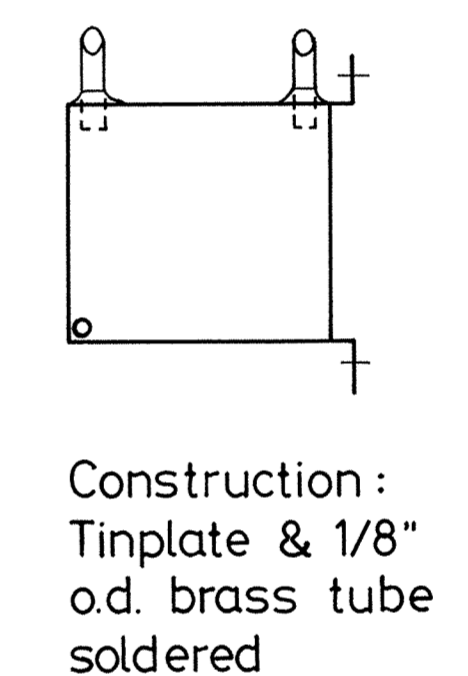

**FUEL TANK**

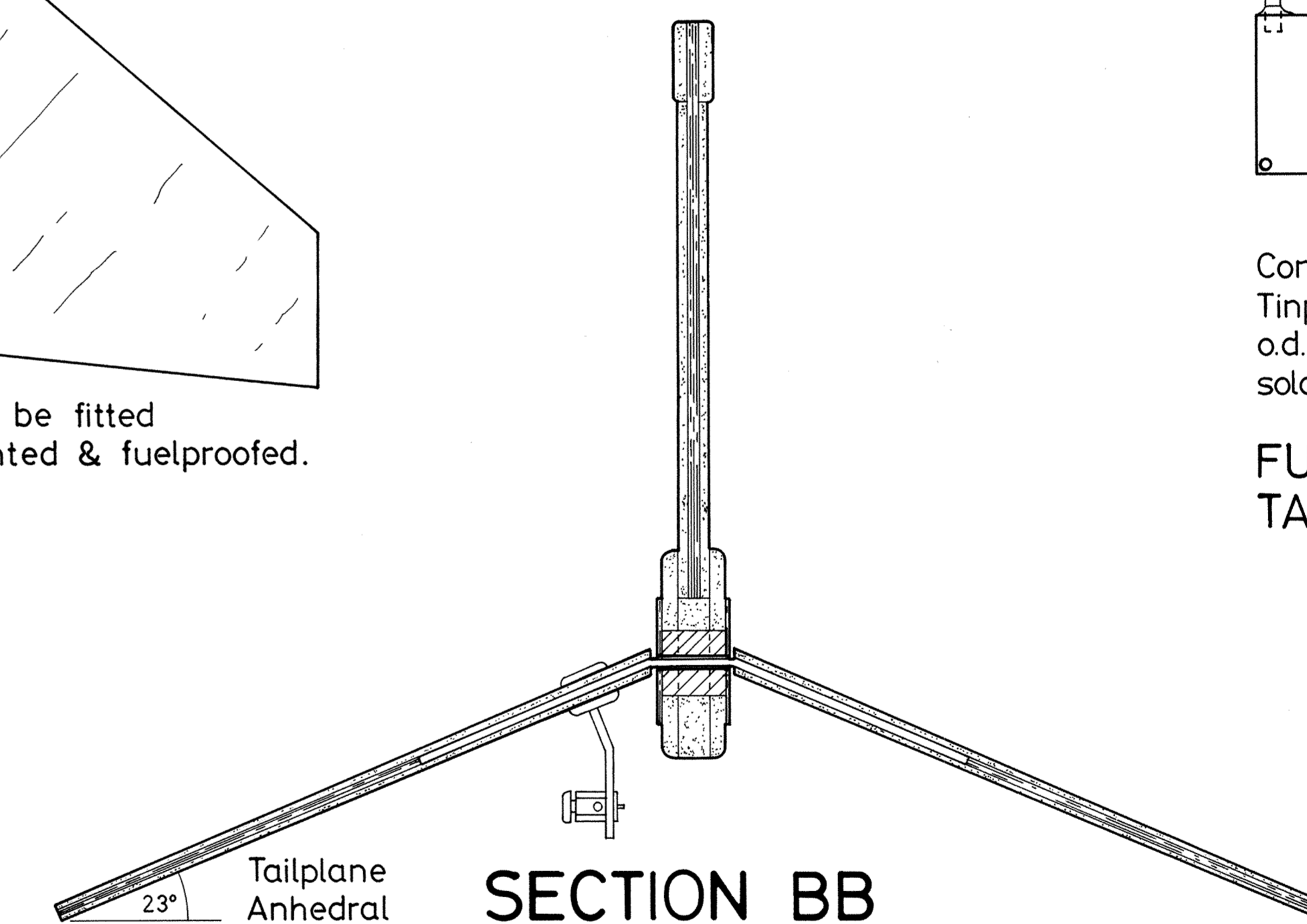

**MCDONNELL DOUGLAS**

**F-4 PHANTOM II**

27 1/2 in. WINGSPAN PROFILE SCALE  
CONTROL LINE MODEL FOR  
0.19cu. in. (3.2cc) ENGINES  
Designed & drawn by E. Stephen